

430-BARREL STEEL OPEN TOP STORAGE TANKS



ADLER 430-BARREL (18,060 GALLON) STEEL OPEN TOP STORAGE TANKS IS THE MOST INNOVATIVE OPEN TOP TANK IN THE INDUSTRY. THE TANK FEATURES A FULL LENGTH SIDE WALKWAY WITH PERMANENT FIXED HANDRAILS AND A 48" WALL BETWEEN THE OPERATOR AND THE PRODUCT IN THE TANK.

The Adler Open top tank features a bare steel interior with optional weirs. Three side man-ways allow for easy access into the tank for cleaning.

Mechanical Features

- ▶ Integrated full-length walkway
 - No Guardrails to set up or take down
 - No moving parts or pins to break
 - No over height issues
 - Now walking over the product being stored
- ▶ Easy to clean design
 - Smooth Wall Interior
 - No corrugations
 - No internal rods
- ▶ 3 easily accessible side hinged manways
- ▶ 2 front and 1 rear 4 inch valved fill/drain ports
- ▶ Front and rear 3-inch fill line
- ▶ Fixed rear axle for increased maneuverability
- ▶ Nose rail cut-out for easy access when installing hose and fittings

Safety Features

- ▶ Safety Walkway eliminates need to walk on top of product
- ▶ Grip strut stairs to help prevent slipping
- ▶ Rails and stairs are painted safety yellow for high visibility
- ▶ Safe Operation reminder decals attached
- ▶ Attached strapping charts

Options

- ▶ Bolt in Wiers

Comprehensive Service

Adler Tank Rentals provides containment solutions for many hazardous and non-hazardous products. We offer 24-hour emergency service, expert planning assistance, transportation services, tank/box repairs and tank/box cleaning. All of our rental equipment is serviced by experienced Adler technicians and tested to meet the most stringent industry standards.



Strategic Storage Solutions 800-421-7471 www.adlertankrentals.com

STORAGE TANKS | MOBILE LIQUID STORAGE | EMERGENCY LIQUID STORAGE | HAZARDOUS WASTE ENVIRONMENTAL TANKS | FRAC TANKS | ISO TANKS | INDUSTRIAL WASTE TANKS | INDUSTRIAL TANKS SOLUTIONS STORAGE TANKS | WASTE STORAGE TANKS | HAZARDOUS SOLUTION STORAGE TANKS OSHA TANKS | NESHAP TANKS | EMERGENCY RESPONSE TANKS | STORAGE TANKS | MOBILE LIQUID

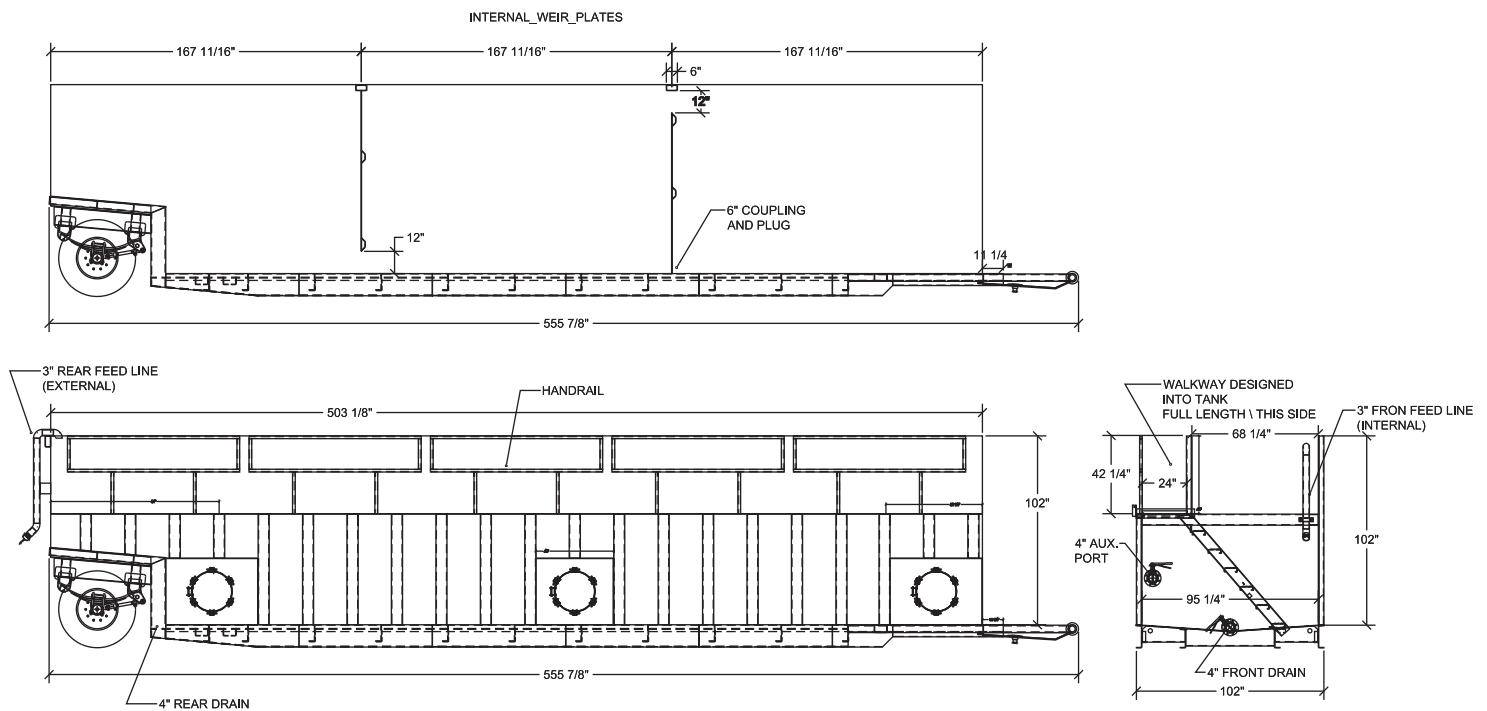

Application Description

Product to be Stored _____

Mixture of Chemicals _____

Rinse Water _____

pH _____

Non Hazardous

Hazardous (describe fully) _____

Temperature _____

Estimated Duration of Rental _____



Strategic Storage Solutions 800-421-7471 www.adlertankrentals.com

STORAGE TANKS | MOBILE LIQUID STORAGE | EMERGENCY LIQUID STORAGE | HAZARDOUS WASTE ENVIRONMENTAL TANKS | FRAC TANKS | ISO TANKS | INDUSTRIAL WASTE TANKS | INDUSTRIAL TANKS SOLUTIONS STORAGE TANKS | WASTE STORAGE TANKS | HAZARDOUS SOLUTION STORAGE TANKS OSHA TANKS | NESHAP TANKS | EMERGENCY RESPONSE TANKS | STORAGE TANKS | MOBILE LIQUID